

STORAGE CONTAINER FOR RECYCLABLE MATERIALS

CAMPUS GOOOL

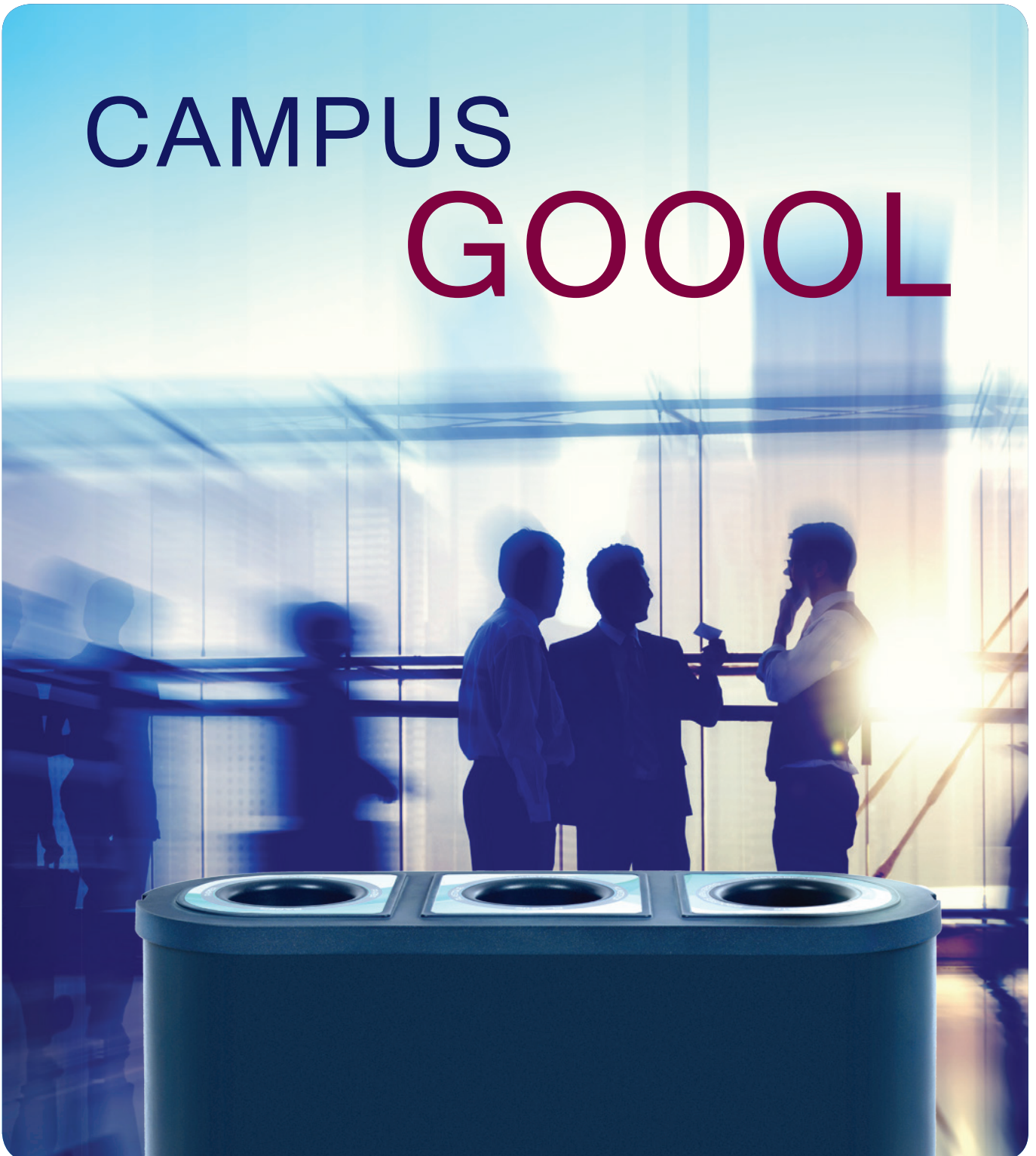

A BULL'S EYE FOR THE ENVIRONMENT

SCORE A SUCCESS!

Eco-friendliness nowadays is an essential part of the self-image of many companies - from environmentally friendly office equipment and sustainable procurement of office materials to ecological business strategies. This also includes the pre-selection of waste and recyclable materials in office buildings. Here functionality is paramount but companies use to set a high value also on an attractive design. CAMPUS GOOOL offers space for three fractions but its slim product design still allows a space-saving integration in passageways and office corridors.

100% SUSTAINABLE

CAMPUS GOOOL is the most sustainable solution for the pre-selection of waste indoors. The bin is completely recyclable, and it can be manufactured from up to 100% recycled material. Its high quality guarantees a long product life. This container makes the collection of various fractions clearly more ergonomic and economic. The improved separation of recyclable materials results in a higher recycling ratio.

AESTHETIC

The classy design of the new CAMPUS GOOOL easily adapts also to a stylish office environment. A choice of material effects and many special colours allow an individual look which adapts to the respective interior design without affecting it negatively. Markings and labels on the cover and side areas can be adapted to the corresponding company design.



Detail photo of inner container

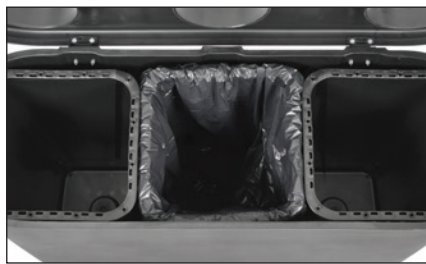

Inner container with rubbish bags



Adjustable hinges

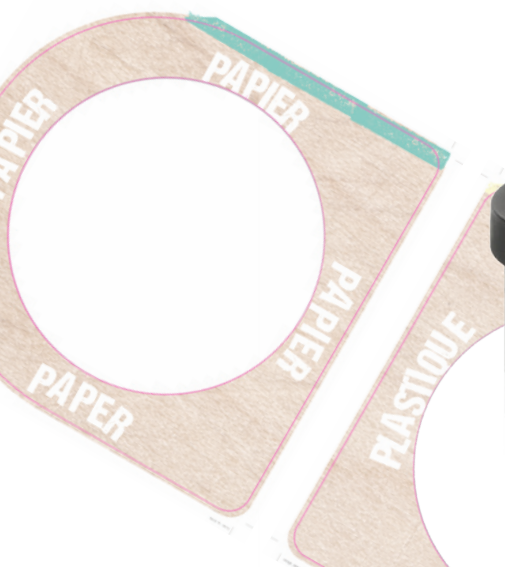

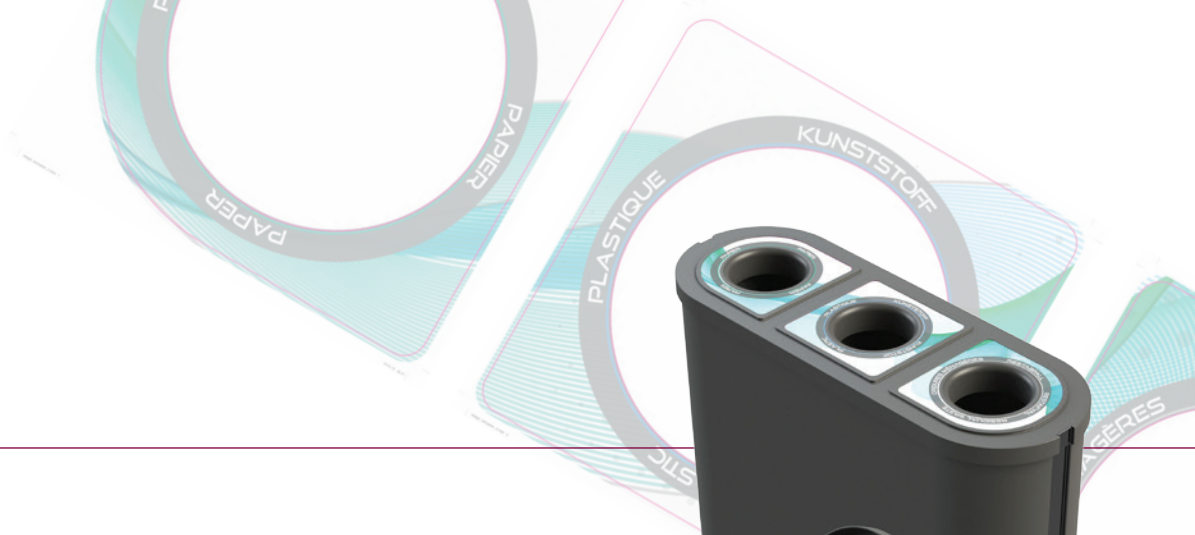

ENVIRONMENTALLY FRIENDLY

- A sustainable solution for environmentally oriented companies
- 100% recyclable
- Highest quality for a long product life
- Economical and ecological - a single waste container replaces a large number of waste-paper baskets
- Clearly reduced costs for emptying
- Fewer rubbish bags needed
- Better exploitation of recyclables due to the higher sorting accuracy which in turn leads to a higher recycling ratio
- Production is possible from up to 100% recycled material

FUNCTIONAL

- Liquid-tight
- Three removable 45 L inner containers
- Surfaces are easy to clean
- Covers are attached to the body with hinges, which can be locked in any position
- Easy to move
- Does not damage the floor
- An easily operable and hygienic solution
- Ready-to-use delivery, each bin individually packed



INDIVIDUAL

- Various material effects
- Individual design of labels and markings
- Different insertion openings are possible
- Many special colours available

	Capacity	3 x 45 L
	Material	HDPE / also producible from 100% recycling material
	Weight	20 kg
	Dimensions H x W x D	755 mm x 1100 mm x 385 mm
	Surfaces	Structured surface, material effects
	Options	Individual deposit opening, many special colours are possible

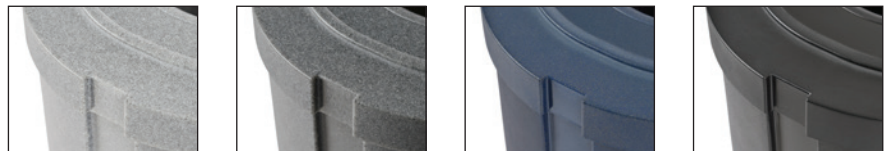

ESE - WE VALUE YOUR RECYCLABLES



KERBSIDE SYSTEMS
MOBILE CONTAINERS FOR
WASTE AND RECYCLABLES



BRING SYSTEMS
(SEMI-) UNDERGROUND SYSTEMS
COLLECTION BANKS



BIO SELECT LINE
CONTAINERS AND COMPOSTERS
FOR GARDEN AND BIO WASTE



HAZARDOUS WASTE CONTAINERS
MOBILE FUEL CONTAINERS
MOBILE OIL CHANGE UNITS



PUBLIC FURNISHING
BINS FOR THE PUBLIC SPACE



CONTAINER MANAGEMENT
DISTRIBUTION, REGISTRATION,
COLLECTION AND RECYCLING

ESE is Europe's leading manufacturer of temporary storage solutions for waste and recyclables. Our comprehensive range of products is complemented by a full service offer from container management to the recycling of products at the end of their lifetime. Specialists in all departments develop solutions to meet our customers' requirements. In doing so, we follow the principle of highest possible sustainability from product development and production to transport.